

DATA SHEET

DVT 3.80

ROTARY VANE PRESSURE/VACUUM PUMPS

oil-free

air-cooled

MAKE IT BECKER.



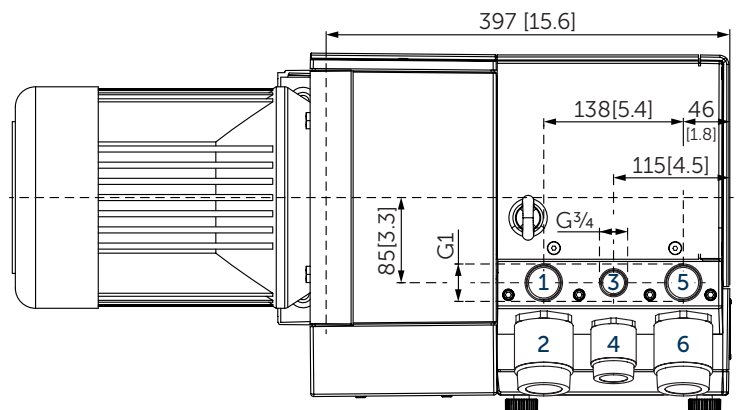
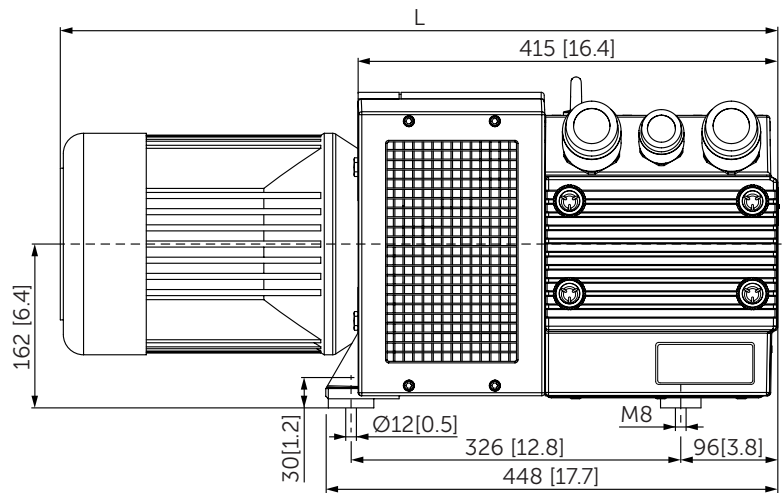
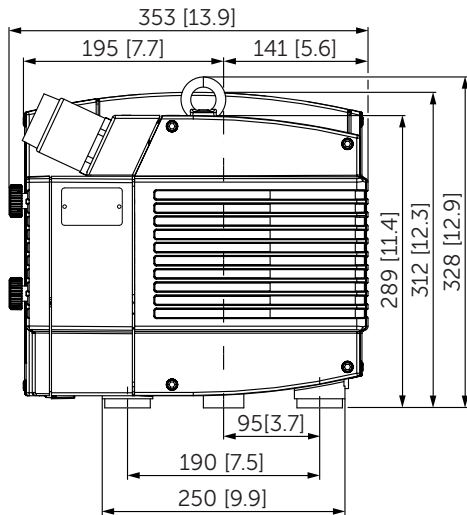

- 1 Pressure connection (G1)
- 2 Pressure regulating valve
- 3 Option: second suction (G³/₄)
- 4 Option: vacuum regulating valve for second suction
- 5 Vacuum connection (G1)
- 6 Vacuum regulating valve
- Including integrated suction air filter
- The motor illustration may vary.
- Dimensions in mm [inch]

Air rate		Pressure/vacuum relative		Motors		Emission sound pressure level ¹⁾		Weight w/o motor
m ³ /h		bar		kW		dB(A)		kg
50 Hz	60 Hz	50 Hz	60 Hz	50 Hz	60 Hz	50 Hz	60 Hz	
70	82	±0.5	±0.5	4.0	4.5–4.8	75–76	76–77	49
70	82	±0.6	±0.6	4.0	4.5–4.8	75–76	76–77	49

¹⁾ According to DIN EN ISO 3744 (KpA = 3 dB(A)), 1 m [39.4 inch] distance, at medium load, both connection sides piped

3~ Motors												L		
#	50 Hz					60 Hz				Version	Weight kg	mm [inch]		
	kW	V	min ⁻¹	A	kW	V	min ⁻¹	A						
01	4.0	Δ230/Y400	IE3	1445	15.5/8.9	4.8	Δ265/Y460		1745	14.9/8.6		IP55 • ISO F • bimetal	34.0	829.0 [32.7]
							Δ230/Y400			15.9/9.2				
02	4.0	Δ200/Y400	IE3	1465	18.0/9.0	4.5	YY230/Y460	IE3	1759	18.4/9.2		UL(E235514) • CSA CC329B IP55 • ISO F • bimetal	40.0	862.0 [34.0]
							YY208	IE3	1753	18.7				
03						4.8	YY230/Y460	IE3	1781	15.4/8.9		UL(E235514) • CSA CC329B IP55 • ISO F • bimetal	58.0	901.5 [35.5]
							YY208		1770	18.4				
04	4.0	Δ200/Y350	IE3	1467	20.3/11.7	4.5	Δ220/Y380-400	IE3	1760	18.5/10.7–10.2		UL(E235514) • CSA CC329B IP55 • ISO F • bimetal	40.0	862.0 [34.0]
							Δ200/Y350	IE3	1753	19.0/11.0				
05						4.5	Δ400/Y690	IE3	1768	11.0/6.35		UL(E235514) • CSA CC329B IP55 • ISO F • bimetal	40.0	862.0 [34.0]
06						4.8	Δ400/Y690	IE3	1775	10.75/6.2		UL(E365362) • CSA IP55 • ISO F • bimetal	64.5	966.5 [38.1]

▪ Current consumption and rotation speed may vary. Tolerance in each case -1.5/+2%

Air rates • power consumptions • temperatures											
relative pressure			relative vacuum								
			50 Hz				60 Hz				
			0 bar	-0.4 bar	-0.5 bar	-0.6 bar	0 bar	-0.4 bar	-0.5 bar	-0.6 bar	
+0.4 bar	Suction air rate	m ³ /h	64	32.5	25	18	77.7	40.7	31.9	23.8	
	Blast air rate	m ³ /h	66	51.9	47.5	43.1	82.7	63	56.8	50.9	
	Power consumption	kW	2.12	2.58	2.65	2.72	2.92	3.33	3.36	3.38	
	Temperature compressed air	°C	41	45	46	47	44	48	49	49	
+0.5 bar	Suction air rate	m ³ /h	63.9	32.2	25	18.1	76.5	40.6	31.9	23.4	
	Blast air rate	m ³ /h	65	51.4	47.1	43	81.4	62.9	56.8	50.6	
	Power consumption	kW	2.18	2.65	2.74	2.8	2.93	3.38	3.44	3.46	
	Temperature compressed air	°C	41	47	47	48	44	49	51	50	
+0.6 bar	Suction air rate	m ³ /h	63	32	24.7	17.5	76	40.6	31.6	23.5	
	Blast air rate	m ³ /h	64.8	51.1	46.8	42.3	80.6	62.5	56	50.2	
	Power consumption	kW	2.26	2.75	2.82	2.91	3.01	3.48	3.52	3.57	
	Temperature compressed air	°C	43	46	48	48	46	51	51	51	

Reference data (atmosphere): 1000 mbar (100 kPa), 20°C (68°F)

Tolerance: ±5%

Air temperature: 5°C ... 45°C (41°F ... 135°F)

+ VARIANTS AND ACCESSORIES

- With first and second suction
- With external suction filter¹⁾
- Sound proof box SH 13¹⁾



Example for an external suction filter



Sound proof box SH 13

¹⁾ See separate data sheet

- Possible combinations on request



MAKE IT BECKER.