

DATA SHEET

U 5.301 O2-PACK ROTARY VANE- VACUUM PUMPS

oil-lubricated

air-cooled

MAKE IT BECKER.

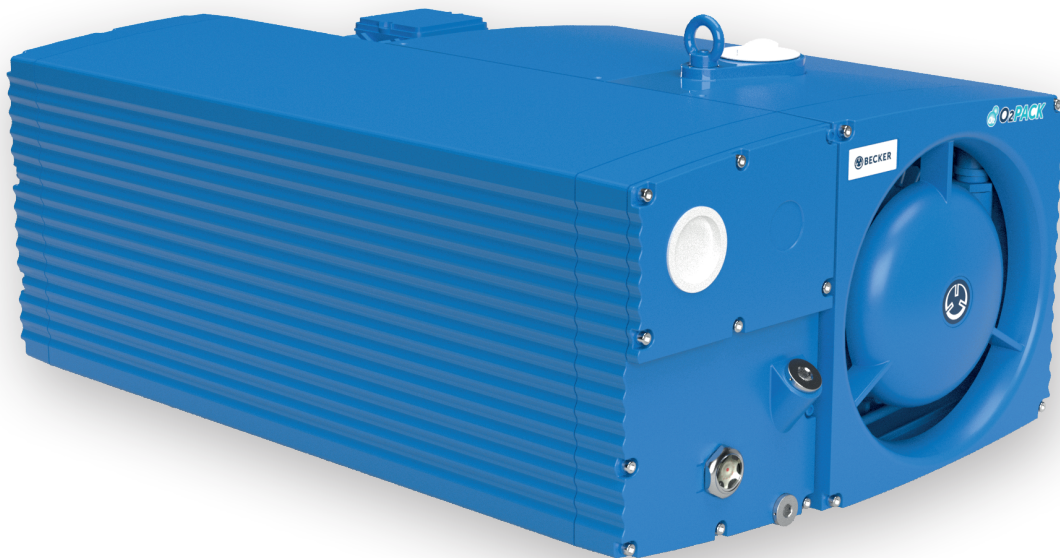

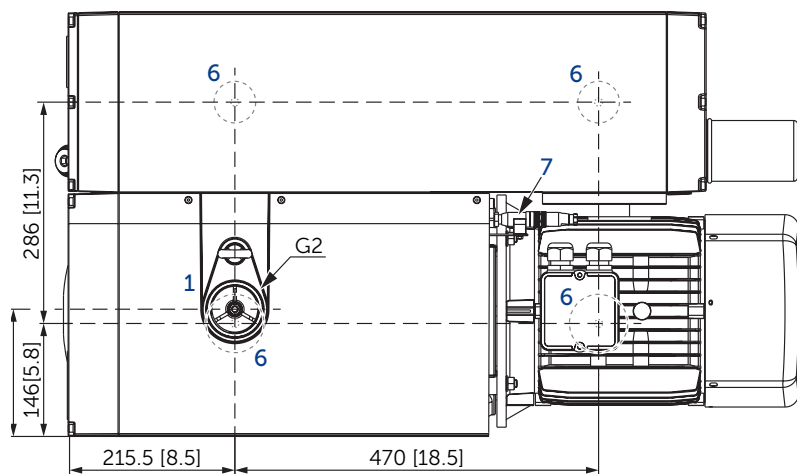
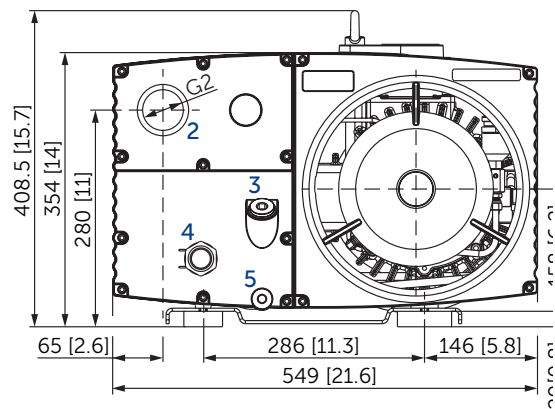
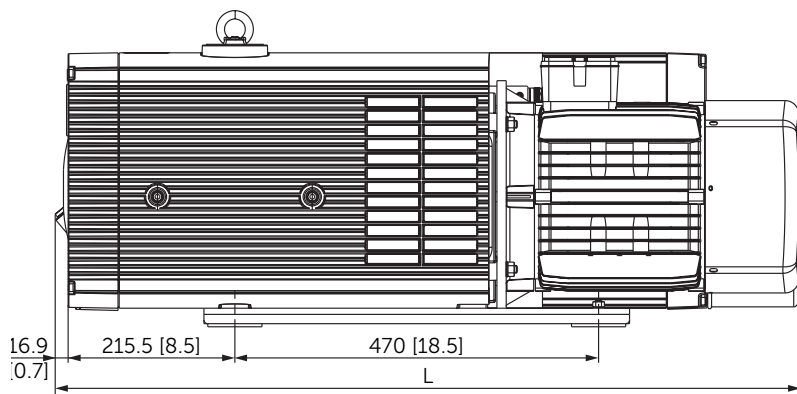

- 1 Vacuum connection (G2)
- 2 Exhaust air connection (G2)
- 3 Oil filter cap (G³/₄)
- 4 Oil sight glas (G1)
- 5 Screw plug for oil drain (G¹/₂)
- 6 Rubber buffer position
 - incl. gas ballast valve, non-return valve, oil separator and oil filter
 - The motor illustration may vary
 - Dimensions in mm [inch]

Nominal capacity		Vacuum absolute for continous operation		Emission sound pressure level ¹⁾		Weight incl. motor	Oil Fomblin® YL VAC 25/6
m ³ /h		mbar		dB(A)		kg	l
50 Hz	60 Hz	50 Hz	60 Hz	50 Hz	60 Hz		
300	360	<0.5-100	<0.5-100	73	76	≈205	6 (11.4 kg)

3~ Motors											L
#	50 Hz				60 Hz				Version	Weight kg	mm [inch]
	kW	V	min ⁻¹	A	kW	V	min ⁻¹	A			
01	5.5	Δ230/Y400	IE3 1468	20.7/12.0	6.6	Δ265/Y460 Δ230/Y400	IE3 1762 - 1750	20.6/11.9 21.6/12.5	IP 55 • ISO F • bimetal	53.0	946.0 [37.3]
02	5.5	Δ400	IE3 1468	12.3	6.6	Δ460 Δ400	IE3 1764 - 1751	12.0 12.4	IP 55 • ISO F • bimetal	53.0	946.0 [37.3]
03					6.6	YY230/Y460 YY208	IE3 1755 - 1750	22.1/11.1 23.3	UL (E235514) • CSA CC329B IP 55 • ISO F • bimetal	55.0	973.5 [38.4]
04	5.5	Δ200/Y350	IE3 1474	27.4/15.8	6.6	Δ200/Y380-400 Δ200/Y350	IE3 1769 - 1761	24.1/14.5-13.8 25.4/14.65	IP 55 • ISO F • bimetal	63.5	984.0 [38.8]
05					6.6	Δ400	IE3 1765	24.1/14.5-13.8 25.4/14.65	UL (E235514) • CSA CC329B IP 55 • ISO F • bimetal	70.8	973.5 [38.4]

¹⁾ According to DIN EN ISO 11203, accuracy class of measurement: class 2, extended measurement uncertainty: 3 dB
 1 m [39.4 inch] distance, at medium load, both connection sides piped
 ▪ Gas ballast valve: water vapour tolerance max. 40 mbar; water vapour capacity max. 5.0/5.6 l/h 50/60 Hz (at 85°C operating temperature)
 ▪ Current consumption and rotation speed may vary. Tolerance in each case -1.5/+2%

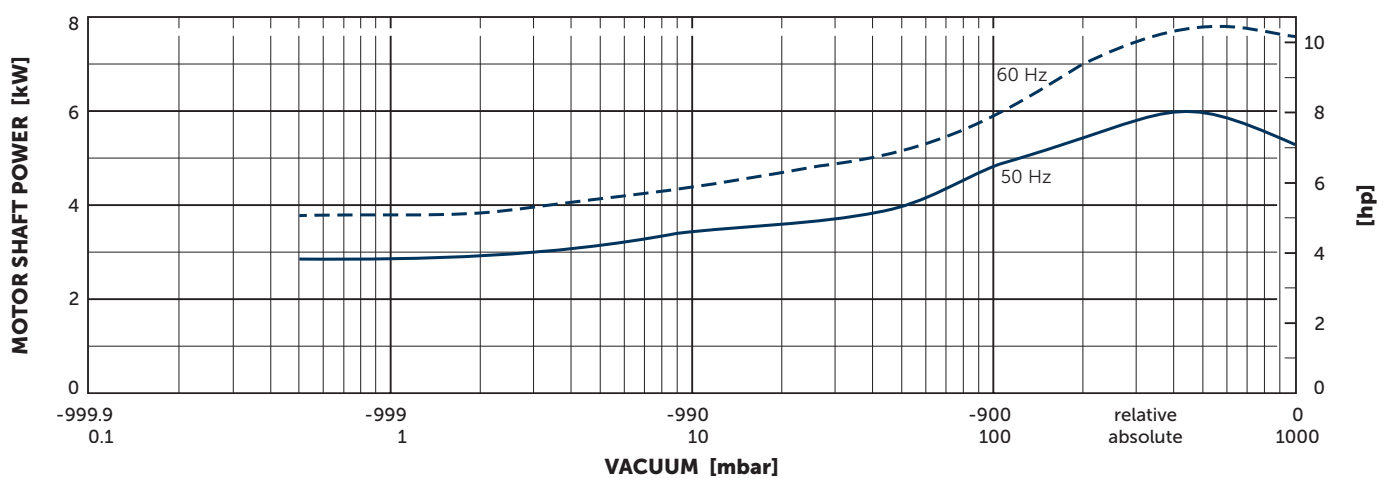
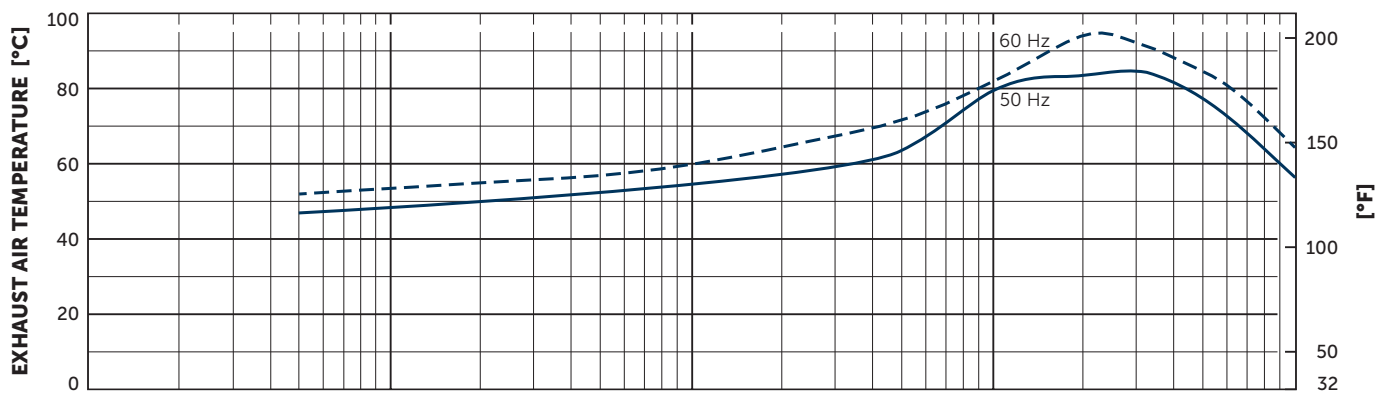
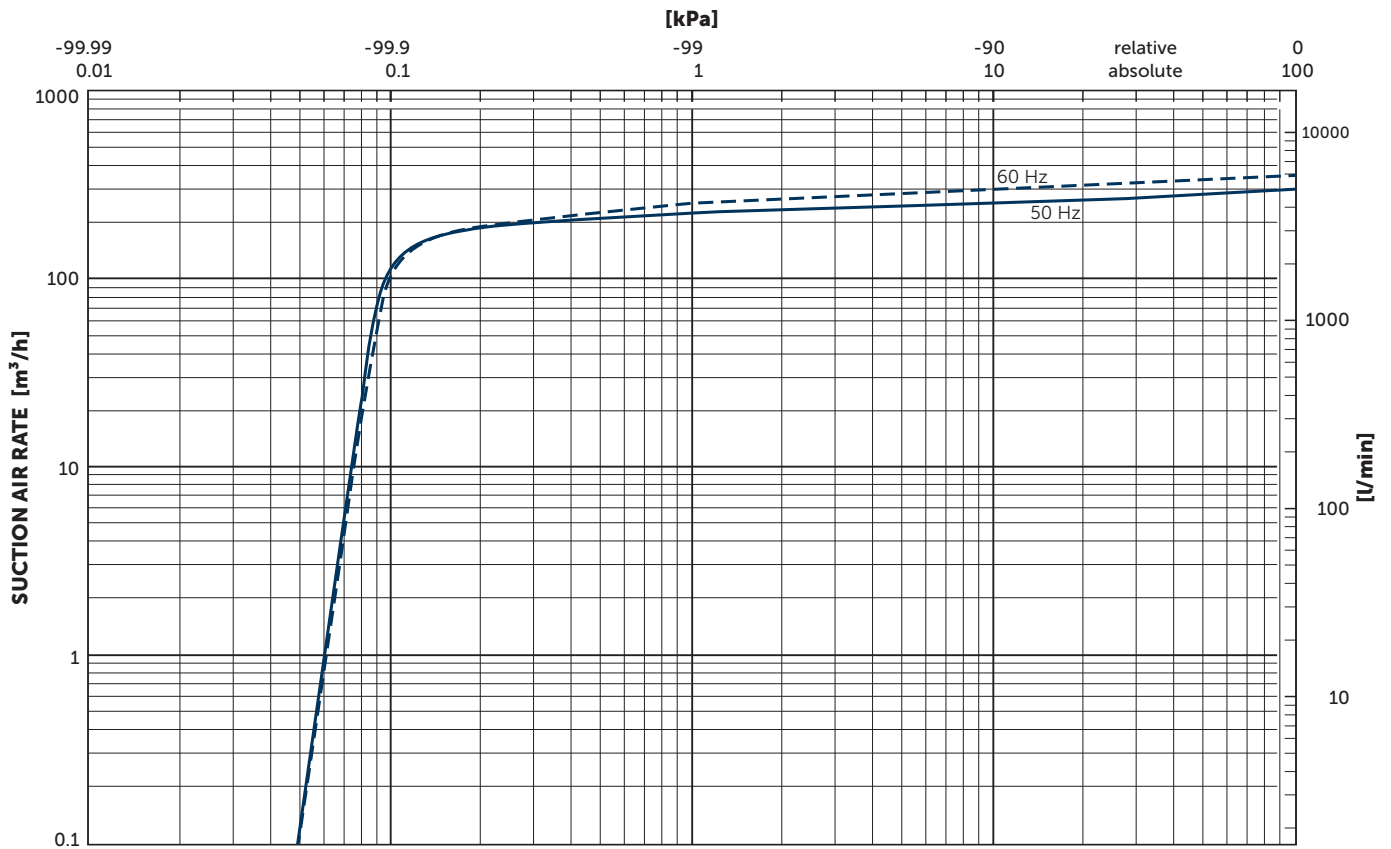

Suction air rate refers to the intake pressure
 Reference data (atmosphere): 1000 mbar (100 kPa), 20°C (68°F)
 Tolerance: ±10%



MAKE IT BECKER.