

**DATA SHEET**

**VARIAIR K VX 3.80/0-400**

**ROTARY VANE  
VACUUM PUMPS**

oil-free, air-cooled  
frequency inverter

---

**MAKE IT BECKER.**

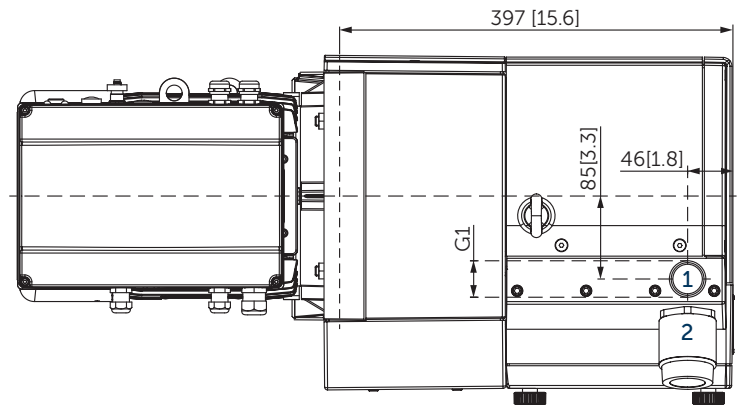
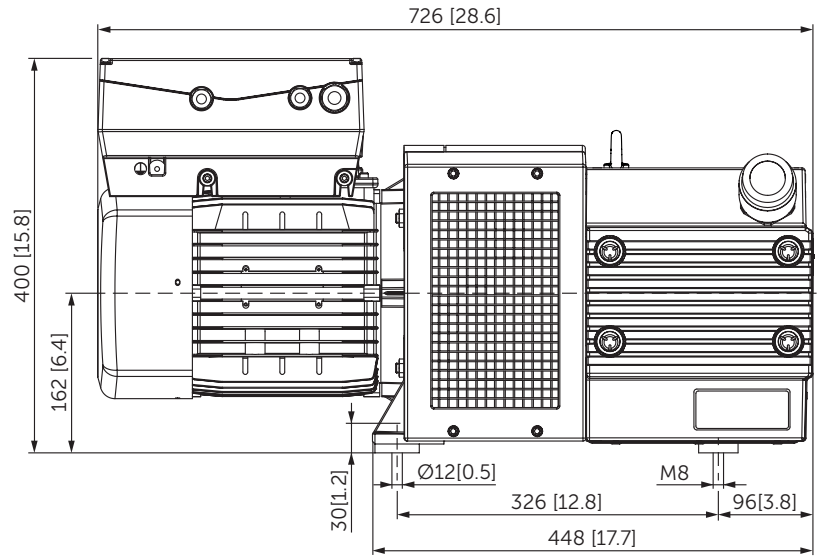
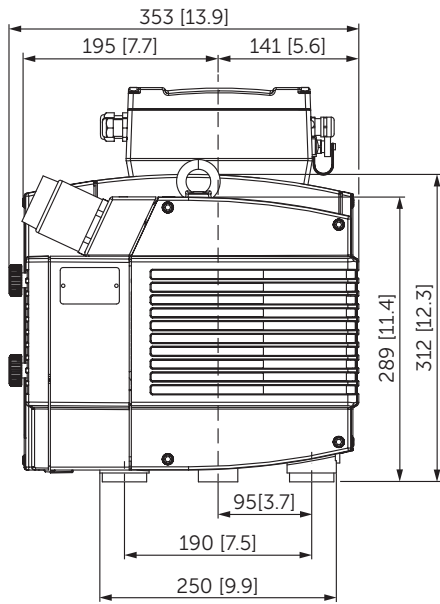

- 1 Vacuum connection (G1)
- 2 Vacuum regulating valve
  - Including integrated suction air filter and blow-off valve
  - The motor illustration may vary.
  - Dimensions in mm [inch]

Suction air rate	Vacuum absolute	Frequency	Emission sound pressure level <sup>1)</sup>	Weight	Frequency inverter VAU4/4	A max.
m <sup>3</sup> /h max.	mbar max.	Hz	dB(A)	kg	4.0 kW 400–480 V ±10% 50/60 Hz	6
76	100	30–60	67	88.5		

<sup>1)</sup> According to DIN EN ISO 3744 (KpA = 3 dB(A)), 1 m [39.4 inch] distance, at medium load, both connection sides piped

### SERIES X: BECKER INNOVATION WITH TOP WARRANTY

Equipped with specially developed vanes, these oil-free rotary vane pumps distinguish themselves by high abrasion resistance, and with that extremely long service lives. Due to the low wear there is also minimal dust, so the series X pumps are perfectly suited for precision processes under clean room conditions.

This innovation branded by Becker is outstanding not only because of its 100

percent oil-free operation, excellent degree of efficiency and low power consumption.

In the area of sensitive vacuum, series X also guarantees precise low-pulsation air conduction.

Becker guarantees for these pumps a vane life-time of 20,000 operating hours or a maximum of 3 years. The enhanced longevity of X series pumps also extends service life intervals, and can cut out the need for frequent service visits with costly pump failures now no longer an issue.



### ADVANTAGES

- Quick, clean and quiet
- Oil-free
- Wear resistant
- Energy saving
- Long-life reliability

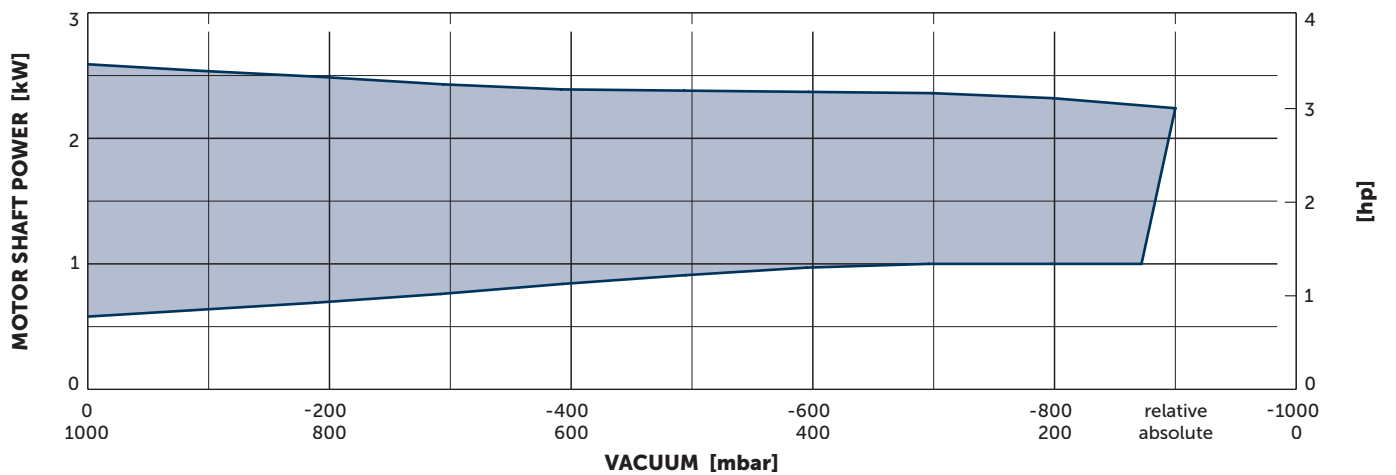
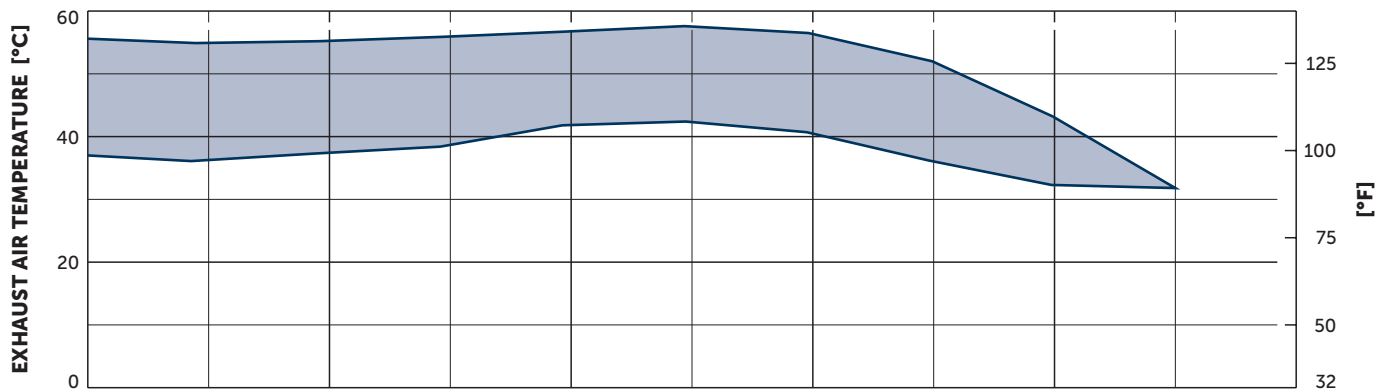
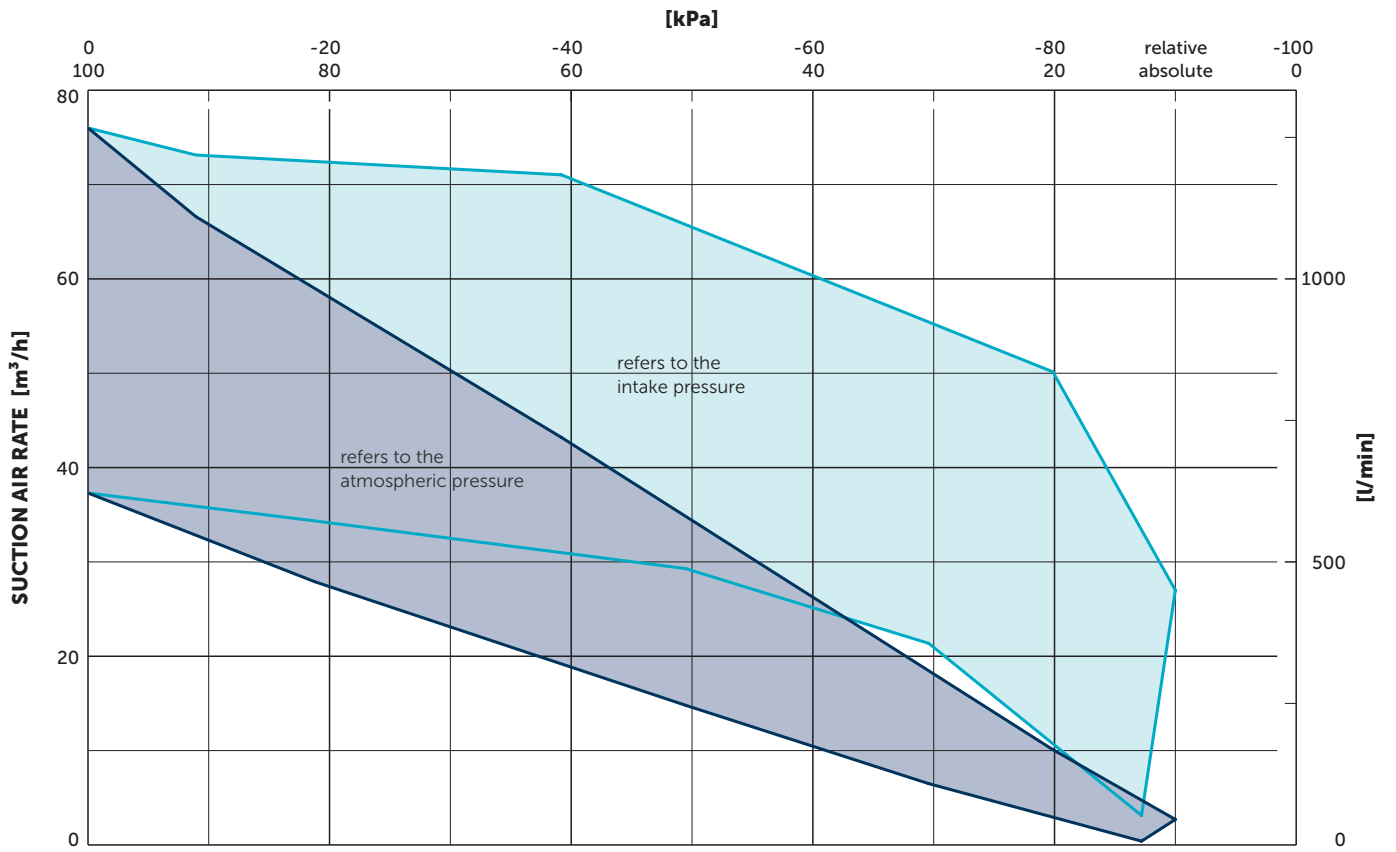

Reference data (atmosphere): 1000 mbar (100 kPa), 20°C (68°F)  
 Tolerance: ±5%



**MAKE IT BECKER.**